



USER MANUAL

UP Series | Thermopile Power Detectors

Warranty

First Year Warranty

The Gentec-EO thermal power and energy detectors carry a one-year warranty (from date of shipment) against material and /or workmanship defects when used under normal operating conditions. The warranty does not cover recalibration or damages related to misuse.

Gentec-EO will repair or replace at its option any wattmeter or joulemeter which proves to be defective during the warranty period, except in the case of product misuse.

Any unauthorized alteration or repair of the product is also not covered by the warranty.

The manufacturer is not liable for consequential damages of any kind.

In the case of a malfunction, contact the local Gentec-EO distributor or nearest Gentec-EO office to obtain a return authorization number. Return the material to the appropriate address below.

Contacting Gentec Electro-Optics Inc.

To help us answer your calls more efficiently please have the model number of the detector you are using ready before calling Customer Support.

All customers:

Gentec-EO, Inc.
445 St-Jean-Baptiste, Suite 160
Quebec, QC, G2E 5N7
Canada

Tel: (418) 651-8003
Fax: (418) 651-1174
Email: service@gentec-eo.com
Web: www.gentec-eo.com

Lifetime Warranty

Gentec-EO will warranty any thermal power and energy detector head for its lifetime as long as it has been returned for recalibration annually from the date of shipment. This warranty includes parts and labor for all routine repairs including normal wear under normal operating conditions.

Gentec-EO will inspect and repair the detector during the annual recalibration. Exceptions to repair at other times will be at Gentec-EO's option.

Not included is the cost of annual recalibration or consequential damages from using the detector.

The only condition is that the detector head must not have been subject to unauthorized service or damaged by misuse. Misuse would include, but is not limited to, laser exposure outside Gentec-EO's published specifications, physical damage due to improper handling, and exposure to hostile environments. Hostile environments would include, but are not limited to excessive temperature, vibration, humidity, or surface contaminants; exposure to flame, solvents or water; and connection to improper electrical voltage.

TABLE OF CONTENTS

WARRANTY I

First Year Warrantyi

Lifetime Warranty.....i

TABLE OF CONTENTS..... II

LIST OF ILLUSTRATIONS..... III

1 ULTRA SERIES UP POWER DETECTORS 1

1.1 INTRODUCTION1

1.2 POWER DETECTOR CONNECTORS.....2

1.2.1 DB-15 “intelligent” connector2

1.2.4 OEM Molex connector (E0 version).....3

1.2.5 Molex connector (MT version)4

1.2.6 Molex-BNC (BT version)5

1.2.7 Molex connector without amplification or anticipation (M0 version)6

1.2.8 Trim pot (CP version)6

1.3 ULTRA SERIES UP, XLP SERIES SPECIFICATIONS7

1.4 UP CALORIMETER MODE SPECIFICATIONS25

1.5 UP POTENTIOMETER POSITIONS.....27

1.6 USING A CUSTOMER-SUPPLIED HEAT SINK.....28

2 OPERATING INSTRUCTIONS 31

2.1 WITH ANY GENTEC-EO MONITOR.....32

2.2 WITHOUT A GENTEC-EO MONITOR.....32

2.3 SAFETY OPERATION NOTES..... 33

Diffusive surfaces33

Detector temperature while in operation.....33

3 DAMAGE TO THE OPTICAL ABSORBER MATERIAL..... 33

APPENDIX A: WEEE DIRECTIVE..... 34

DECLARATION OF CONFORMITY 35

APPENDIX B: USING THE XLP12 WITH THE XLP12 FILTER: 36

APPENDIX C: USING THE XLP12 WITH AN OPTICAL FIBER ADAPTOR: 38

LIST OF ILLUSTRATIONS

FIG. 1-1 DB-15 CONNECTOR PIN-OUT2
FIG. 1-2 BNC CONNECTOR.....3
FIG. 1-3 MOLEX CONNECTOR PIN-OUT IN E0 VERSION3
FIG. 1-4 MOLEX CONNECTOR PIN-OUT IN MT VERSION.....4
FIG. 1-5 MOLEX CONNECTOR PIN-OUT IN MT-B VERSION.....4
FIG. 1-6 FEMALE MOLEX CONNECTOR KIT FOR MT AND MO VERSIONS4
FIG. 1-7 MOLEX CONNECTOR PIN-OUT IN BT VERSION.....5
FIG. 1-8 MOLEX CONNECTOR PIN-OUT IN M0 VERSION6
FIG. 1-9 MAX AVERAGE POWER DENSITY FOR UP WITH H-TYPE ABSORBER AT 1.064 μ M.24
FIG. 1-10 MINIMUM BEAM SIZES FOR UP WITH H-TYPE ABSORBER AT 1.064 μ M.24
FIG. 1-11 POTENTIOMETER POSITIONS27
FIG. 1-12 TAPPED HOLE POSITIONS FOR UP12E, WITHOUT PCB29
FIG 1-13 TAPPED HOLE POSITIONS FOR UP19K.....29
FIG 1-14 TAPPED HOLE POSITIONS FOR UP25N, UP50N(M), UP55N(M), AND UP60(M).....30
FIG. 1-15 XLP12 FILTER SPECIFICATIONS37
FIG. 1-16 USING AN OPTICAL FIBER ADAPTOR.....38

1 ULTRA SERIES UP POWER DETECTORS

1.1 INTRODUCTION

The Gentec-EO Ultra Series UP power detector family includes thirteen series (XLP12, UP12E, UP10K(P), UP17P, UP19K, UP25N(M), UP25T, UP50N(M), UP55N(M), UP55C, UP60N(M), UP55G, and UP60G) of opto-thermal sensors with different cooling options (stand alone, heat sink, fan and water), with or without amplification. The high power surface absorber sensors are designed for use at high average power densities.

Unit	Aperture	Exterior dimensions	Power range
	mm	mm	(without amplification)
XLP12	12	73 x 73	1 μ W to 3 W
UP10P	10	46 x 46	0.1 mW to 2 W
UP10K	10	50 x 50	0.1 mW to 2 W
UP12E	12	38 x 38	1 mW to 70 W
UP17P	17	46 x 46	1 mW to 6 W
UP19K,UP10K (H5 ; H9 ; VR ; W5)	10 ; 19 ; 19 ; 18 ; 17	50 x 50	0.2 mW to 200 W
UP25N(M)	25	89 x 89	3 mW to 350 W
UP25T	25	62.4 x 62.4	10 mW to 250 W
UP50N(M)	50	89 x 89	5 mW to 50 W
UP55N(M)	55	89 x 89	5 mW to 700 W
UP55G	55	120 x 120	15 mW to 600 W
UP55C	55	116 X 116	0.2 W to 2500 W
UP60N(M)	60	89 x 89	5 mW to 700 W
UP60G	60	120 x 120	15 mW to 600 W

The UP detectors are supplied with a 180 cm length flexible cable with output connection options of a DB-15 "intelligent" male connector, an Integra USB connector, a BNC connector, a Molex connector and a BNC/Molex connector. A few exception exist: the UP50N series is available with BNC/Molex connector on special order only and the XLP12, UP60N(M), and UP60G series are only supplied with a DB-15 "intelligent" male connector and the Integra USB connector.

NOTE: To eliminate possible damage, do not carry the detector using the connector cable.

The UP detectors may also be supplied with a stand. Be aware that when using a detector with a heat sink, the fins should always be placed vertically.

For cases where Gentec-EO's monitors don't automatically read the wavelength correction factor, you can use your detector's "*Personal wavelength correction™ Certificate*" to adjust the power you read to a power corrected for a particular wavelength.

Call your nearest Gentec-EO distributor to replace the sensor disk and/or to recalibrate the head. For Gentec-EO's nearest office contact information, see p. ii, **Contacting Gentec Electro-Optics Inc.**

1.2 POWER DETECTOR CONNECTORS

1.2.1 DB-15 "intelligent" connector

The DB-15 male "intelligent" connector contains an EEPROM (Electrically Erasable Programmable Read-Only Memory) with different information such as the model of the detector, the calibration sensitivity, the applicable scales and the wavelength correction factor for up to 20 wavelengths related to the Ultra Series UP detector head in use.

This connector, available in the UP without amplification, allows the TPM-300CE, DUO (model of the detector, calibration sensitivity and scale), SOLO and MAESTRO (model of the detector, calibration sensitivity, scale and wavelength correction factor) monitors to adjust their characteristics automatically to the power sensor being connected. No calibration procedure is required when installing the power heads, allowing for faster set-up.

The DB-15 connector pin-out is composed of (see Fig. 1-1):

1-	USED BY MONITOR
2-	" " " " "
3-	" " " " "
4-	" " " " "
5-	" " " " "
6-	SIGNAL (+)
7-	USED BY MONITOR
8-	" " " " "
9-	" " " " "
10-	" " " " "
11-	" " " " "
12-	" " " " "
13-	SIGNAL (-)
14-	USED BY MONITOR
15-	" " " " "

SHELL - BODY GROUND

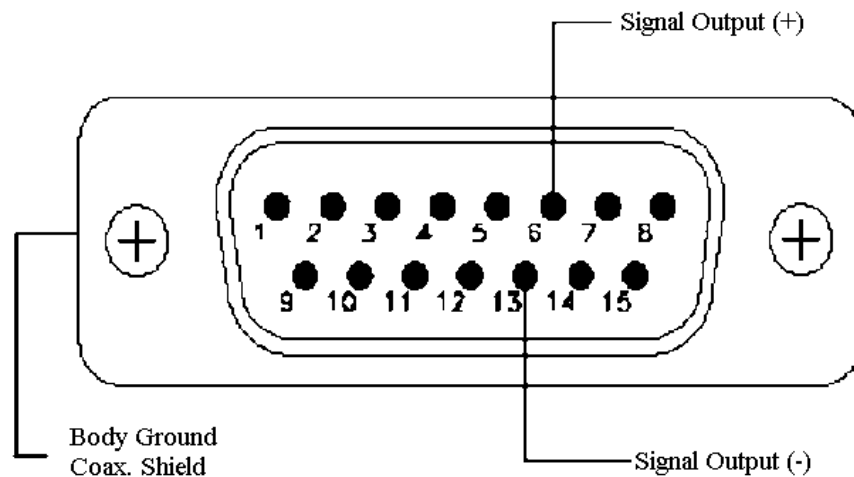

FIG. 1-1 DB-15 CONNECTOR PIN-OUT

1.2.2 Integra USB connector

The Integra USB Connector is an integrated monitor that allows to plug the head directly into a computer. It has the same serial commands as the MAESTRO and a few extra one's (see the PC-Gentec-EO Manual) and uses the same PC-Gentec-EO software. All specifications are mostly the same, except for:

Wattmeter and joulemeter heads have a noise ~ 1.3 x higher.

The risetime of the UP12 head (with anticipation) is slower by 0.2 seconds.

1.2.3 BNC connector

The BNC connector is quick and easy to install and is the best at shielding EMI noise.

The BNC connector allows you to connect the detector directly on an oscilloscope or to a precision microvoltmeter with the correct load impedance. The connector is available in the UP detectors without amplification (load impedance: 100 k Ω) and with the Molex connector in the amplified version (load impedance : 10 M Ω).

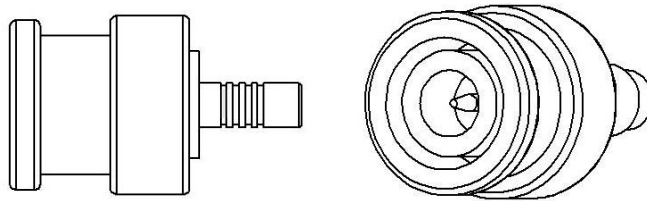

FIG. 1-2 BNC CONNECTOR

1.2.4 OEM Molex connector (E0 version)

The Molex female connector is available in the UP19-xxx-H5 and UP12E-xxx-H5 without amplification (load impedance : 100 k Ω). It allows you to connect to an external PCB board available at Gentec-EO.



FIG. 1-3 MOLEX CONNECTOR PIN-OUT IN E0 VERSION

1.2.5 Molex connector (MT version)

The Molex male connector, available in the UP with amplification, allows you to power the internal circuit board (PCB) and to read the signal with your own electronics.

The PCB needs +12 to +16V from a regulated power supply but **does not** need negative voltage.



FIG. 1-4 MOLEX CONNECTOR PIN-OUT IN MT VERSION

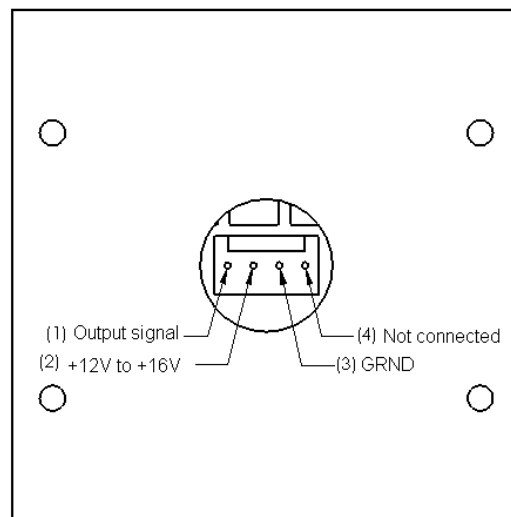

FIG. 1-5 MOLEX CONNECTOR PIN-OUT IN MT-B VERSION

Make your own molex cable for use with OEM heads. Product number : 202170

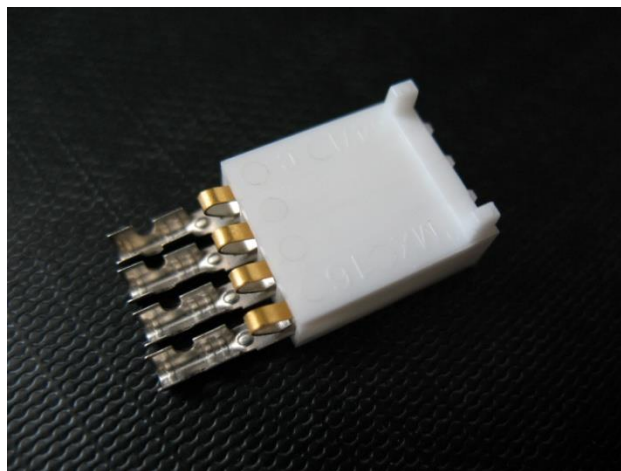

FIG. 1-6 FEMALE MOLEX CONNECTOR KIT FOR MT AND MO VERSIONS

1.2.6 Molex-BNC (BT version)

The Molex-BNC connection, available in the UP with amplification, allows you to power the internal circuit board (PCB) with the Molex connector and to read the signal with the BNC connector (load impedance : 10 $\text{M}\Omega$). The PCB needs +12 to +16V from a regulated power supply but **does not** need negative voltage.

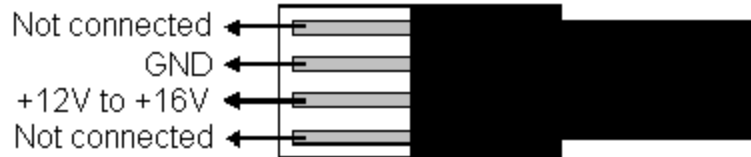

FIG. 1-7 MOLEX CONNECTOR PIN-OUT IN BT VERSION

1.2.7 Molex connector without amplification or anticipation (M0 version)

The Molex male connector, available in the UP without amplification, allows you to read the signal with your own electronics.

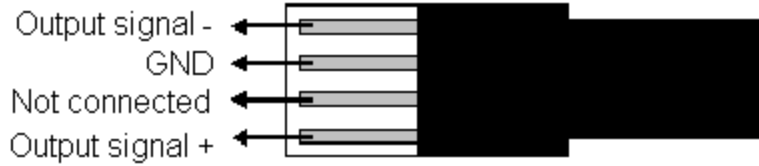

FIG. 1-8 MOLEX CONNECTOR PIN-OUT IN M0 VERSION

1.2.8 Trim pot (CP version)

The detector with trim pot and BNC connector (recommended load impedance: 10 M Ω), available in the UP10K, UP12E, UP19K, UP25N, UP25T and UP55N without amplification, allows you to have the same sensitivity for all your detector.

Detector	Sensitivity
UP10K-2S-H5	1.60 mV/W
UP12E-10S-H5	0.42 mV/W
UP19K-xxx-H5	0.52 mV/W
UP19K-xxx-H9	0.23 mV/W
UP19K-xxx-VR	0.34 mV/W
UP19K-xxx-W5	0.53 mV/W
UP25N-xxx-H9	0.18 mV/W
UP25T-xxx-H12	0.10 mV/W
UP55N-xxx-H9	0.09 mV/W
UP55C-xxx-HD	0.008 mV/W

1.3 ULTRA SERIES UP, XLP SERIES SPECIFICATIONS

The following specifications are based on a one-year calibration cycle, an operating temperature of 15 to 28°C and a relative humidity not exceeding 80%. Storage 10 to 65°C and relative humidity not exceeding 90%.

Water quality requirements (for water-cooled detector)

- The diameter of the particule in the water must be below 60µm.
(Gentec-eo can provide an external water filter 202990 if water quality is an issue)
- The resistivity of the water must be over 100 kOhm-cm.
- The hardness must be below 10ppm.
- The PH must be between 6.0 to 8.0.
(Low PH will remove the protective oxide layer)

XLP12-...-3S-H2	XLP12-3S-H2		XLPF12-3S-H2	
Effective Aperture Diameter	12 mm			
Spectral Range	0.19 µm – 20 µm		0.28 µm – 2.1 µm	
Calibrated spectral range	0.248 – 2.5 µm and 10.6 µm ^b		0.308 – 2.1 µm ^a	
Power Noise Level ^{c, d}	± 0.5 µW			
Thermal Drift ^e	12 µW/°C		6 µW/°C	
Typical Rise time (0-95%)	27 s (2.5 s with anticipation)			
Typical sensitivity	200 mV/W		180 mV/W	
Calibration Uncertainty	± 2.5 %			
Linearity with Power	± 2 %			
Repeatability (Precision)	± 0.5 %			
Power Resolution	± 0.5 %			
Max. Average Power	3 W			
Max. Average Power (1 min) (cooling : minimum 3 min)	3 W			
Max. Average Power Density 1.064 µm, 1 W CW	1 kW/cm ²			
<u>Pulsed Laser Damage Thresholds</u>	<u>Max. Energy Density</u>		<u>Peak Power Density</u>	
1.064 µm, 360 µs, 5 Hz	5 J/cm ²		14 kW/cm ²	
1.064 µm, 7 ns, 10 Hz	1 J/cm ²		143 MW/cm ²	
532 nm, 7 ns, 10 Hz	0.6 J/cm ²		86 MW/cm ²	
266 nm, 7 ns, 10 Hz	0.3 J/cm ²		43 MW/cm ²	
Dimensions (H x W x D, in mm)	With isol. tube: 73 x 73 x 72	W/o isol. tube: 73 x 73 x 20	With isol. tube: 73 x 73 x 80	W/o isol. tube: 73 x 73 x 28
Weight (head only, with isolation tube)	0.312 kg		0.324 kg	
Cooling	Heat sink			
Recommended load Impedance	100 kΩ			
Output Impedance	N. A.			
Linearity vs beam dimension	± 0.7 %			
Power supply range (VDD)	N. A.			
Max output signal	N. A.			

^a Except 1350 – 1450 nm.

^b The calibrations at 2.1 to 2.5 µm and 10.6 µm are on special request only. The traceability at 248 nm is obtained with the help of a traceable reference at 250 nm, since our spectrophotometer has a 4 nm spectral bandwidth at 248 nm.

^c Nominal value, actual value depends on electrical noise in the measurement system.

^d Without anticipation. ± 5 µW with anticipation.

^e At 150 µW. 12 µW/°C for XLP12 with SOLO, 50 µW/°C for XLP12 with P-LINK.

Specifications subject to change without notice.

...12-...-3S-VP	XLP12-3S-VP	
Effective Aperture Diameter	12 mm	
Spectral Range	0.248 – 20 μm	
Calibrated spectral range	0.248 – 2.5 μm ^b	
Power Noise Level ^{c, d}	$\pm 0.5 \mu\text{W}$	
Thermal Drift ^e	12 $\mu\text{W}/^\circ\text{C}$	
Typical Rise time (0-95%)	30 s (3.0 s with anticipation)	
Typical sensitivity	220 mV/W	
Calibration Uncertainty	$\pm 2.5\%$ @ 1.064 μm $\pm 3.5\%$ @ 0.25-2.5 μm	
Linearity with Power	$\pm 2\%$	
Repeatability (Precision)	$\pm 0.5\%$	
Power Resolution	$\pm 0.5\%$	
Max. Average Power	3 W	
Max. Average Power (1 min) (cooling : minimum 3 min)	3 W	
Minimum Repetition Rate	7 Hz with Antipation 1 Hz without Anticipation	
Max. Average Power Density 1 W CW	30 W/cm ² @ 1.064 μm 8 W/cm ² @ 0.532 μm 4 W/cm ² @ 0.355 μm	
<u>Pulsed Laser Damage Thresholds</u> 1.064 μm , 7 ns, 10 Hz 532 nm, 7 ns, 10 Hz 355 nm, 7 ns, 10 Hz	<u>Max. Energy Density</u> 4 J/cm ² 3 J/cm ² 1 J/cm ²	
Dimensions (H x W x D, in mm)	With isol. tube: 73 x 73 x 72	W/o isol. tube: 73 x 73 x 20
Weight (head only, with isolation tube)	0.316 kg	
Cooling	Heat sink	
Recommended load Impedance	100 k Ω	
Output Impedance	N. A.	
Linearity vs beam dimension	$\pm 0.7\%$	
Power supply range (VDD)	N. A.	
Max output signal	N. A.	

^a Except 1350 – 1450 nm.

^b The calibrations at 2.1 to 2.5 μm and 10.6 μm are on special request only. The traceability at 248 nm is obtained with the help of a traceable reference at 250 nm, since our spectrophotometer has a 4 nm spectral bandwidth at 248 nm.

^c Nominal value, actual value depends on electrical noise in the measurement system.

^d Without anticipation. $\pm 5 \mu\text{W}$ with anticipation.

^e At 150 μW . 12 $\mu\text{W}/^\circ\text{C}$ for XLP12 with SOLO, 50 $\mu\text{W}/^\circ\text{C}$ for XLP12 with P-LINK.

Specifications subject to change without notice.

UP(F)10P-2S-H5-L	UP10P-2S-H5-L	UPF10P-2S-H5-L
Effective Aperture Diameter	10 mm	
Spectral Range	0.19 – 20 μm	0.28 μm – 2.1 μm
Calibrated spectral range	0.248 – 2.5 μm and 10.6 μm ^a	0.308 – 2.1 μm ^b
Power Noise Level	0.2 mW with anticipation 0.1 mW without anticipation 30 μW with anticipation and moving average mode (2 sec)	
Typical Rise time (0-95%)	3.0 s (1.4 s with anticipation)	
Typical sensitivity	2 mV/W	1.8 mV/W
Calibration Uncertainty	$\pm 2.5\%$	
Linearity with Power	$\pm 2\%$	
Repeatability (Precision)	$\pm 0.5\%$	
Power Resolution	$\pm 0.5\%$	
Max. Average Power	2 S: 2 W	
Max. Average Power (1 min) (cooling : minimum 3 min)	2 S: 2 W	
<u>Max. Average Power Density</u> ^c 1.064 μm , 2W CW 10.6 μm , 2W CW	36 kW/cm ² 11 kW/cm ²	
<u>Pulsed Laser Damage Thresholds</u> 1.064 μm , 360 μs , 5 Hz 1.064 μm , 7 ns, 10 Hz 532 nm, 7 ns, 10 Hz 266 nm, 7 ns, 10 Hz	<u>Max. Energy Density</u> 5 J/cm ² 1.0 J/cm ² 0.6 J/cm ² 0.3 J/cm ²	<u>Peak Power Density</u> 14 kW/cm ² 143 MW/cm ² 86 MW/cm ² 43 MW/cm ²
Dimensions (mm)	46(H) x 46(W) x 13(D)	46(H) x 46(W) x 21.4(D)
Weight (head only)	2S: 0.13 kg	2S: 0.14 kg
Cooling	Stand alone	
Recommended load Impedance	100 k Ω	
Output Impedance	N. A.	
Linearity vs beam dimension	$\pm 0.7\%$	
Power supply range (VDD)	N. A.	
Max output signal	N. A.	

^a The calibrations at 2.1 to 2.5 μm and 10.6 μm are on special request only. The traceability at 248 nm is obtained with the help of a traceable reference at 250 nm, since our spectrophotometer has a 4 nm spectral bandwidth at 248 nm.

^b Except 1350 – 1450 nm.

^c See graph at the end of this section.

Specifications subject to change without notice.

UP(F)10K-2S-H5-L	Without PCB	With PCB
Effective Aperture Diameter	10 mm	
Spectral Range	UP10K : 0.19 – 20 μm UPF10K : 0.28 μm – 2.1 μm	
Calibrated spectral range	UP10K : 0.248 – 2.5 μm and 10.6 μm ^a UPF10K : 0.308 – 2.1 μm ^b	
Power Noise Level	0.2 mW with anticipation 0.1 mW without anticipation 30 μW with anticipation and moving average mode (2 sec)	0.2 mW with anticipation 0.1 mW without anticipation
Typical Rise time (0-95%)	3.0 s (1.1 s with anticipation)	
Typical sensitivity	UP10K : 2 mV/W UPF10K : 1.8 mV/W	2 V/W
Calibration Uncertainty	$\pm 2.5\%$	
Linearity with Power	$\pm 2\%$	
Repeatability (Precision)	$\pm 0.5\%$	
Power Resolution	$\pm 0.5\%$	
Max. Average Power	2 S : 2 W	
Max. Average Power (1 min) (cooling : minimum 3 min)	2 S : 2 W	
<u>Max. Average Power Density</u> ^c 1.064 μm , 2W CW 10.6 μm , 2W CW	36 kW/cm ² 11 kW/cm ²	
<u>Pulsed Laser Damage Thresholds</u> 1.064 μm , 360 μs , 5 Hz 1.064 μm , 7 ns, 10 Hz 532 nm, 7 ns, 10 Hz 266 nm, 7 ns, 10 Hz	<u>Max. Energy Density</u> 5 J/cm ² 1.0 J/cm ² 0.6 J/cm ² 0.3 J/cm ²	<u>Peak Power Density</u> 14 kW/cm ² 143 MW/cm ² 86 MW/cm ² 43 MW/cm ²
Dimensions (mm)	UP10K : 50(H) x 50(W) x 21.5(D) UPF10K : 50(H) x 50(W) x 30(D)	UP10K : 50(H) x 50(W) x 27(D) UPF10K : 50(H) x 50(W) x 35(D)
Weight (head only)	UP10K : 0.13 kg UPF10K : 0.14 kg	UP10K : 0.20 kg UPF10K : 0.21 kg
Cooling	Stand alone	
Recommended load Impedance	100 k Ω	10 M Ω
Output Impedance	N. A.	$\leq 50\ \Omega$
Linearity vs beam dimension	$\pm 0.7\%$	
Power supply range (VDD)	N. A.	+ 12 V to + 16 V regulated
Max output signal	N. A.	VDD (supply)-3V, max of 12V

^a The calibrations at 2.1 to 2.5 μm and 10.6 μm are on special request only. The traceability at 248 nm is obtained with the help of a traceable reference at 250 nm, since our spectrophotometer has a 4 nm spectral bandwidth at 248 nm.

^b Except 1350 – 1450 nm.

^c See graph at the end of this section.

Specifications subject to change without notice.

UP12E-...-H5-...	10S / 20H / 70W -H5 Without PCB	10S -H5 With PCB
Effective Aperture Diameter	12 mm	
Spectral Range	0.19 – 20 μm	
Calibrated spectral range ^a	0.248 – 2.5 μm and 10.6 μm	
Power Noise Level	2 mW with anticipation 1 mW without anticipation	0.5 mW with anticipation ^d 0.25 mW without anticipation ^d
Typical Rise time (0-95%)	1.6 s (0.3 s with anticipation)	0.3 s (with anticipation)
Typical sensitivity	0.53 mV/W	400 mV/W
Calibration Uncertainty	$\pm 2.5\%$	
Linearity with Power	$\pm 2\%$	
Repeatability (Precision)	$\pm 0.5\%$	
Power Resolution	$\pm 0.5\%$	
Max. Average Power	10S: 10 W 20H: 20 W 70W: 70 W	10S: 10 W
Max. Average Power (1 min) (cooling : minimum 3 min)	10S: 20 W 20H: 40 W 70W: 110 W	10S: 20 W
<u>Max. Average Power Density</u> ^b 1.064 μm , 10W CW 10.6 μm , 10W CW	36 kW/cm ² 11 kW/cm ²	
<u>Pulsed Laser Damage Thresholds</u> 1.064 μm , 360 μs , 5 Hz 1.064 μm , 7 ns, 10 Hz 532 nm, 7 ns, 10 Hz 266 nm, 7 ns, 10 Hz	<u>Max. Energy Density</u> 5 J/cm ² 1.0 J/cm ² 0.6 J/cm ² 0.3 J/cm ²	<u>Peak Power Density</u> 14 kW/cm ² 143 MW/cm ² 86 MW/cm ² 43 MW/cm ²
Dimensions (mm)	10S: 38(H) x 38 (W) x 14 (D) 20H: 38(H) x 38 (W) x 45 (D) 70W: 38(H) x 38 (W) x 32 (D)	10S: 38(H) x 38 (W) x 36.6 (D)
Weight (head only)	10S: 0.13 kg 20H: 0.15 kg 70W: 0.19 kg	10S: 0.20 kg
Minimum Cooling Flow ^c	0.5 liter/min	N. A.
Recommended Cooling Flow ^c	1.0 liter/min	N. A.
Cooling	Heat sink / water	Stand alone
Recommended load Impedance	100 k Ω	10 M Ω
Output Impedance	N. A.	$\leq 50\ \Omega$
Linearity vs beam dimension	$\pm 0.7\%$	
Power supply range (VDD)	N. A.	+ 12 V to + 16 V regulated
Max output signal	N. A.	VDD (supply)-3V, max of 12V

^a The calibrations at 2.1 to 2.5 μm and 10.6 μm are on special request only. The traceability at 248 nm is obtained with the help of a traceable reference at 250 nm, since our spectrophotometer has a 4 nm spectral bandwidth at 248 nm.

^b See graph at the end of this section.

^c Water temperature $\leq 22^\circ\text{C}$, 1/8 NPT compression fittings for 1/4 inch semi-rigid tube.

^d Noise level measured using P-LINK (USB). Noise level is dependant on acquisition system.

Specifications subject to change without notice.

UP17P-6S-H5	UP17P-6S-H5	
Effective Aperture Diameter	17 mm	
Spectral Range	190 nm – 20 μ m	
Calibrated spectral range ^a	0.248 – 2.5 μ m and 10.6 μ m	
Power Noise Level ^b	2 mW with anticipation 1 mW without anticipation	
Typical Rise time (0-95%)	2.5 s (0.8 s with anticipation)	
Typical sensitivity ^c	0.6 mV/W	
Calibration Uncertainty ^d	± 2.5 %	
Linearity with Power	± 2 %	
Repeatability (Precision)	± 0.5 %	
Power Resolution	± 0.5 %	
Max. Average Power	6 W	
Max. Average Power (1 min) (cooling : minimum 3 min)	7 W	
Max. Average Power Density ^e	36 kW/cm ² 11 kW/cm ²	
1.064 μ m, 10 W CW		
10.6 μ m, 10 W CW		
<u>Pulsed Laser Damage Thresholds</u>	<u>Max. Energy Density</u>	<u>Peak Power Density</u>
1.064 μ m, 360 μ s, 5 Hz	5 J/cm ²	14 kW/cm ²
1.064 μ m, 7 ns, 10 Hz	1.0 J/cm ²	143 MW/cm ²
532 nm, 7 ns, 10 Hz	0.6 J/cm ²	86 MW/cm ²
266 nm, 7 ns, 10 Hz	0.3 J/cm ²	43 MW/cm ²
Dimensions (mm)	46H x 46 (W) x 10.7 (D)	
Weight (head only)	0.1 kg	
Recommended load Impedance	100 k Ω	
Output Impedance	N.A.	
Linearity vs beam dimension	± 0.5 %	
Power supply range (VDD)	N.A.	
Max output signal	N.A.	

^a The calibrations at 2.1 to 2.5 μ m and 10.6 μ m are on special request only. The traceability at 248 nm is obtained with the help of a traceable reference at 250 nm, since our spectrophotometer has a 4 nm spectral bandwidth at 248 nm.

^b Nominal value, actual value depends on electrical noise in the measurement system.

^c Maximum output voltage = sensitivity x maximum power

^d Including linearity with power

^e See graph at the end of this section

Specifications subject to change without notice.

UP17P-6S-W5	UP17P-6S-W5	
Effective Aperture Diameter	17 mm	
Spectral Range	190 nm – 10 μ m	
Calibrated spectral range ^a	0.248 – 2.5 μ m	
Power Noise Level ^b	2 mW with anticipation 1 mW without anticipation	
Typical Rise time (0-95%)	5 s (1.4 s with anticipation)	
Typical sensitivity	0.6 mV/W	
Calibration Uncertainty ^c	\pm 2.5 %	
Linearity with Power	\pm 2 %	
Repeatability (Precision)	\pm 0.5 %	
Power Resolution	\pm 0.5 %	
Max. Average Power	6 W	
Max. Average Power (1 min) (cooling : minimum 3 min)	7 W	
Max. Average Power Density ^d 1.064 μ m, 10 W CW	100 kW/cm ²	
<u>Pulsed Laser Damage Thresholds</u>	<u>Max. Energy Density</u>	<u>Peak Power Density</u>
1.064 μ m, 150 μ s, 5 Hz	100 J/cm ²	667 kW/cm ²
1.064 μ m, 7 ns, 10 Hz	1.1 J/cm ²	157 MW/cm ²
532 nm, 7 ns, 10 Hz	1.1 J/cm ²	157 MW/cm ²
266 nm, 26 ns, 10 Hz	0.7 J/cm ²	27 MW/cm ²
Dimensions (mm)	46(H) x 46(W) x 10.7(D)	
Weight (head only)	0.1 kg	
Recommended load Impedance	100 k Ω	
Output Impedance	N.A.	
Linearity vs beam dimension	\pm 0.5 %	
Power supply range (VDD)	N.A.	
Max output signal	N.A.	

^a The calibrations at 2.1 to 2.5 μ m are on special request only. The traceability at 248 nm is obtained with the help of a traceable reference at 250 nm, since our spectrophotometer has a 4 nm spectral bandwidth at 248 nm.

^b Nominal value, actual value depends on electrical noise in the measurement system.

^c Including linearity with power

^d See graph at the end of this section

Specifications subject to change without notice.

UP19K-...-Hx-...	15S / 30H / 50L / 100DI / 150W -H5 15S / 110F / 150DI / 200W -H9 Without PCB	15S / 30H / 50L / 100DI / 110F / 150W -H5 and 15S / 110F / 150DI / 200W -H9 With PCB
Effective Aperture Diameter	19 mm	
Spectral Range	190 nm – 20 µm	
Calibrated spectral range ^a	0.248 – 2.5 µm and 10.6 µm	
Power Noise Level	With anticipation H5 : 2 mW, H9 : 6 mW Without anticipation H5 : 1 mW, H9 : 3 mW	With anticipation H5 : 0.4 mW, H9 : 1.2 mW ^d Without anticipation H5 : 0.2 mW, H9 : 0.6 mW ^d
Typical Rise time (0 - 95 %)	H5 : 2.8 s (0.6 s with anticipation) H9 : 4.5 s (1.5 s with anticipation)	H5 : 0.5 s (with anticipation) H9 : 1.5 s (with anticipation)
Typical sensitivity	H5 : 0.65 mV/W H9 : 0.23 mV/W	15S-H5 : 400 mV/W 15S-H9 : 200 mV/W 30H : 200 mV/W 50L : 120 mV/W 100DI : 55 mV/W 110F : 55 mV/W 150W : 50 mV/W 150DI : 50 mV/W 200W : 30 mV/W
Calibration Uncertainty	± 2.5 %	
Linearity with Power	± 2 %	
Repeatability (Precision)	± 0.5 %	
Power Resolution	± 0.5 %	
Max. Average Power	15S-H5, -H9 : 15 W 30H : 30 W 50L : 50 W 100DI (stainless steel) : 100 W	110F-H9 : 110 W 150W : 150 W 150DI-H9 (stainless steel) : 150 W 200W-H9 : 200 W ^a
Max. Average Power (1 min) (cooling : minimum 3 min)	15S-H5, -H9 : 30 W 30H : 60 W 50L : 90 W 100DI (stainless steel) : 100 W	110F-H9 : 150 W 150W : 190 W 150DI-H9 (stainless steel) : 150 W 200W-H9 : 200 W ^a
Max. Average Power Density ^b 1.064 µm, 10W CW 10.6 µm, 10W CW	H5 : 36 kW/cm ² , H9 : 45 kW/cm ² H5 : 11 kW/cm ² , H9 : 14 kW/cm ²	
<u>Pulsed Laser Damage Thresholds</u> 1.064 µm, 360 µs, 5 Hz 1.064 µm, 7 ns, 10 Hz 532 nm, 7 ns, 10 Hz 266 nm, 7 ns, 10 Hz	<u>Max. Energy Density</u> H5 : 5 J/cm ² , H9 : 9 J/cm ² 1.0 J/cm ² 0.6 J/cm ² 0.3 J/cm ²	<u>Peak Power Density</u> H5 : 14 kW/cm ² , H9 : 25 kW/cm ² 143 MW/cm ² 86 MW/cm ² 43 MW/cm ²
Dimensions (mm)	15S : 50(H) x 50(W) x 20.6(D) 30H : 50(H) x 50(W) x 56.3(D) 50L : 76.2(H) x 76.2(W) x 74.7(D) 100DI : 50(H) x 50(W) x 33(D) 110F : 54.2(H) x 54.2(W) x 55.6(D) 150W : 50(H) x 50(W) x 33(D) 150DI : 50(H) x 50(W) x 33(D) 200W : 50(H) x 50(W) x 33(D)	15S : 50(H) x 50(W) x 25.6(D) 30H : 50(H) x 50(W) x 61.3(D) 50L : 76.2(H) x 76.2(W) x 79.7(D) 100DI : 50(H) x 50(W) x 38(D) 110F : 54.2(H) x 54.2(W) x 60.6(D) 150W : 50(H) x 50(W) x 38(D) 150DI : 50(H) x 50(W) x 38(D) 200W : 50(H) x 50(W) x 38(D)
Weight (head only)	15S : 0.16 kg 30H : 0.21 kg 50L : 0.48 kg 100DI : 0.42 kg	110F : 0.25 kg 150W : 0.24 kg 150DI : 0.42 kg 200W : 0.24 kg
Minimum Cooling Flow ^c	0.5 liter/min	
Recommended Cooling Flow ^c	1.0 liter/min	
Cooling	Heat sink / fan / water	
Recommended load Impedance	100 kΩ	10 MΩ
Output Impedance	N. A.	≤ 50 Ω
Linearity vs beam dimension	± 0.5 %	
Power supply range (VDD)	N. A.	+ 12 V to + 16 V regulated
Max output signal	N. A.	VDD (supply)-3V, max of 12V

^a The calibrations at 2.1 to 2.5 µm and 10.6 µm are on special request only. The traceability at 248 nm is obtained with the help of a traceable reference at 250 nm, since our spectrophotometer has a 4 nm spectral bandwidth at 248 nm.

^b See graph at the end of this section.

^c Water temperature ≤ 22°C, 1/8 NPT compression fittings for ¼ inch semi-rigid tube. For the stainless steel water module, the minimum cooling flow is 1.0 liter/min for power higher than 90 W

^d Noise level measured using P-LINK (USB). Noise level is dependant on acquisition system.

Specifications subject to change without notice.

UP19K-...-VR-...	UP19K-15S / 30H -VR Without PCB	
Effective Aperture Diameter	18 mm	
Spectral Range	0.266 - 2.5 μm	
Calibrated spectral range ^a	0.30 – 2.5 μm	
Power Noise Level	4 mW with anticipation 2 mW without anticipation	
Typical Rise time (0 - 95 %)	36 s (2.5 s with anticipation)	
Typical sensitivity	0.34 mV/W	
Calibration Uncertainty	$\pm 2.5\%$	
Linearity with Power	$\pm 2\%$	
Repeatability (Precision)	$\pm 0.5\%$	
Power Resolution	$\pm 0.5\%$	
Max. Average Power	15S: 15 W 30H: 30 W	
Max. Average Power (1 min.) (cooling : minimum 3 min)	15S: 20 W 30H: 35 W	
Max. Average Power Density 1.064 μm , 10W CW	700 W/cm ²	
<u>Pulsed Laser Damage Thresholds</u>	<u>Max. Energy Density</u>	<u>Peak Power Density</u>
1.064 μm , 7 ns, 10 Hz	6 J/cm ²	860 MW/cm ²
532 nm, 7 ns, 10 Hz	4 J/cm ²	570 MW/cm ²
266 nm, 7 ns, 10 Hz	1 J/cm ²	143 MW/cm ²
1.064 μm , 360 μs , 10 Hz	40 J/cm ²	111 kW/cm ²
Dimension (mm)	15S: 50(H) x 50(W) x 20.6(D) 30H: 50(H) x 50(W) x 56.3(D)	
Weight (head only)	15S: 0.16 kg 30H: 0.21 kg	
Cooling	Heat sink	
Recommended load Impedance	100 k Ω	
Output Impedance	N. A.	
Linearity vs beam dimension	$\pm 0.5\%$	
Power supply range (VDD)	N. A.	
Max output signal	N. A.	

^a The calibrations at 2.1 to 2.5 μm are on special request only. The traceability at 248 nm is obtained with the help of a traceable reference at 250 nm, since our spectrophotometer has a 4 nm spectral bandwidth at 248 nm.

Specifications subject to change without notice.

UP19K-...-W5-...	UP19K-15S / 30H / 50L / 50F / 50W / 50DI -W5 Without PCB	UP19K-15S / 30H / 50L / 50F / 50W / 50DI -W5 With PCB
Effective Aperture Diameter	17 mm	
Spectral Range	190 nm – 10 μ m	
Calibrated spectral range ^a	0.248 – 2.5 μ m	
Power Noise Level	2 mW with anticipation 1 mW without anticipation	0.4 mW with anticipation ^c 0.2 mW without anticipation ^c
Typical Rise time (0-95%)	5 s (1.4 s with anticipation)	
Typical sensitivity	0.65 mV/W	15S: 400 mV/W 30H: 200 mV/W 50L: 120 mV/W 50F: 120 mV/W 50W: 120 mV/W 50DI: 120 mV/W
Calibration Uncertainty	± 2.5 %	
Linearity with Power	± 2 %	
Repeatability (Precision)	± 0.5 %	
Power Resolution	± 0.5 %	
Max. Average Power	15S: 15 W 30H: 30 W 50L: 50 W 50F: 50 W 50W: 50 W 50DI (stainless steel): 50 W	
Max. Average Power (1 min) (cooling: minimum 3 min)	15S: 30 W 30H: 60 W 50L: 85 W 50F: 85 W 50W: 85 W 50DI (stainless steel): 85 W	
Max. Average Power Density 1.064 μ m, 10 W CW	100 kW/cm ²	
<u>Pulsed Laser Damage Thresholds</u> 1.064 μ m, 150 μ s, 10 Hz 1.064 μ m, 7 ns, 10 Hz 532 nm, 7 ns, 10 Hz 248 nm, 26 ns, 10 Hz	<u>Max. Energy Density</u> 100 J/cm ² 1.1 J/cm ² 1.1 J/cm ² 0.7J/cm ²	<u>Peak Power Density</u> 667 kW/cm ² 157 MW/cm ² 157 MW/cm ² 27 MW/cm ²
Dimension (mm)	15S: 50(H) x 50(W) x 20.6(D) 30H: 50(H) x 50(W) x 56.3(D) 50L: 76.2(H) x 76.2(W) x 74.7(D) 50F: 54.2(H) x 54.2(W) x 55.6(D) 50W: 50(H) x 50(W) x 33(D) 50DI: 50(H) x 50(W) x 33(D)	15S: 50(H) x 50(W) x 25.6(D) 30H: 50(H) x 50(W) x 61.3(D) 50L: 76.2(H) x 76.2(W) x 79.7(D) 50F: 54.2(H) x 54.2(W) x 60.6(D) 50W: 50(H) x 50(W) x 38(D) 50DI: 50(H) x 50(W) x 38(D)
Weight (head only)	15S: 0.16 kg 30H: 0.21 kg 50L: 0.48 kg 50F: 0.25 kg 50W: 0.24 kg 50DI: 0.42 kg	15S: 0.20 kg 30H: 0.25 kg 50L: 0.52 kg 50F: 0.29 kg 50W: 0.28 kg 50DI: 0.46 kg
Minimum Cooling Flow ^b	0.5 liter/min	
Recommended Cooling Flow ^b	1.0 liter/min	
Cooling	Heat sink / fan / water	
Recommended load Impedance	100 k Ω	10 M Ω
Output Impedance	N. A.	≤ 50 Ω
Linearity vs beam dimension	± 0.5 %	
Power supply range (VDD)	N. A.	+ 12 V to + 16 V regulated
Max output signal	N. A.	VDD (supply)-3V, max of 12V

^a The calibrations at 2.1 to 2.5 μ m are on special request only. The traceability at 248 nm is obtained with the help of a traceable reference at 250 nm, since our spectrophotometer has a 4 nm spectral bandwidth at 248 nm.

^b Water temperature $\leq 22^{\circ}\text{C}$, 1/8 NPT compression fittings for 1/4 inch semi-rigid tube.

^c Noise level measured using P-LINK (USB). Noise level is dependant on acquisition system.

Specifications subject to change without notice.

UP25N(M)-...-Hx- ...	UP25N-40S / 100H -H9 UP25N-250F-H12 UP25M-350W-H12 Without PCB	UP25N-40S / 100H -H9 UP25N-250F-H12 UP25M-350W-H12 With PCB
Aperture Diameter	25 mm	
Spectral Range	190 nm - 20 μ m	
Calibrated spectral range ^a	0.248 – 2.5 μ m and 10.6 μ m	
Power Noise Level	With anticipation H9 : 6 mW H12 : 20 mW Without anticipation H9 : 3 mW H12 : 10 mW	With anticipation 40S / 100H : 2 mW ^d 250F-H12 : 20 mW ^d 350W-H12 : 20 mW ^d Without anticipation 40S / 100H : 1 mW ^d 250F-H12 : 10 mW ^d 350W-H12 : 10 mW ^d
Typical Rise Time (0 – 95 %)	H9 : 5 s (1.3 s with anticipation) H12 : 7.9 s (1.3 s with anticipation)	H9 : 1.3 s (with anticipation) H12 : 2 s (with anticipation)
Typical sensitivity	H9 : 0.23 mV/W H12 : 0.1 mV/W	40S-H9 : 150 mV/W 100H-H9 : 60 mV/W 250F-H12 : 24 mV/W 350W-H12 : 24 mV/W
Calibration Uncertainty	± 2.5 %	
Linearity with Power	± 2 %	
Repeatability (Precision)	± 0.5 %	
Power Resolution	± 0.5 %	
Max. Average Power	40S : 40 W 100H : 100 W 250F : 250 W 350W : 350 W	
Max. Average Power (1 min) (cooling : minimum 3 min)	40S : 80 W 100H : 200 W 250F : 300 W 350W : 350 W	
Max. Average Power Density ^b 1.064 μ m, 10 W CW 10.6 μ m, 10 W CW	45 kW/cm ² 14 kW/cm ²	
<u>Pulsed Laser Damage Thresholds</u> 1.064 μ m, 360 μ s, 5 Hz 1.064 μ m, 7 ns, 10 Hz 532 nm, 7 ns, 10 Hz 266 nm, 7 ns, 10 Hz	<u>Max. Energy Density</u> 9 J/cm ² 1.0 J/cm ² 0.6 J/cm ² 0.3 J/cm ²	<u>Peak Power Density</u> 25 kW/cm ² 143 MW/cm ² 86 MW/cm ² 43 MW/cm ²
Dimension (mm)	40S : 89(H) x 89(W) x 32(D) 100H : 89(H) x 89(W) x 106(D) 250F : 89(H) x 89(W) x 116(D) 350W : 89(H) x 89(W) x 40(D)	
Weight (head only)	40S : 0.68 kg 100H : 0.99 kg 250F : 1.44 kg 350W : 0.87 kg	
Minimum Cooling Flow ^c	1.5 liter/min	
Cooling	Heat sink / Fan / Water	
Recommended Load Impedance	> 100 k Ω	10 M Ω
Output Impedance	N. A.	≤ 50 Ω
Linearity vs Beam Dimension	± 0.5 %	
Power supply range (VDD)	N. A.	+12 V to +16 V regulated
Max Output Signal	N. A.	VDD (supply)-3V, max of 12V

^a The calibrations at 2.1 to 2.5 μ m and 10.6 μ m are on special request only. The traceability at 248 nm is obtained with the help of a traceable reference at 250 nm, since our spectrophotometer has a 4 nm spectral bandwidth at 248 nm.

^b See graph at the end of this section.

^c Water temperature $\leq 22^\circ\text{C}$, 1/8 NPT compression fittings for 1/4 inch semi-rigid tube.

^d Noise level measured using P-LINK (USB). Noise level is dependant on acquisition system.

Specifications subject to change without notice.

UP25T-...-Hx-...	UP25T-15S / 250W-H12 Without PCB	
Aperture Diameter	25 mm	
Spectral Range	190 nm - 20 μ m	
Calibrated spectral range ^a	0.248 – 2.5 μ m and 10.6 μ m	
Power Noise Level	20 mW with anticipation 10 mW without anticipation	
Typical Rise Time (0-95%)	7.9 s (1.3 s with anticipation)	
Typical sensitivity	0.1 mV/W	
Calibration Uncertainty	\pm 2.5%	
Linearity with Power	\pm 2%	
Repeatability (Precision)	\pm 0.5%	
Power Resolution	\pm 0.5%	
Max. Average Power	15S: 15 W 250W: 250 W	
Max. Average Power (1 min.) (cooling : minimum 3 min)	15S: 15 W 250W: 250 W	
Max. Average Power Density ^b 1.064 μ m, 10W CW 10.6 μ m, 10W CW	45 kW/cm ² 14 kW/cm ²	
<u>Pulsed Laser Damage Thresholds</u> 1.064 μ m, 360 μ s, 5 Hz 1.064 μ m, 7 ns, 10 Hz 532 nm, 7 ns, 10 Hz 266 nm, 7 ns, 10 Hz	<u>Max. Energy Density</u> 9 J/cm ² 1.0 J/cm ² 0.6 J/cm ² 0.3 J/cm ²	<u>Peak Power Density</u> 25 kW/cm ² 143 MW/cm ² 86 MW/cm ² 43 MW/cm ²
Dimension (mm)	62.4(H) x 62.4(W) x 38.1(D)	
Weight (head only)	15S: 0.31 kg 250W: 0.33 kg	
Minimum Cooling Flow ^c	15S: Stand alone 250W: 1.5 liter/min	
Cooling	15S: Stand alone 250W: water	
Recommended load Impedance	> 100 k Ω	
Output Impedance	N. A.	
Linearity vs beam dimension	\pm 0.5 %	
Power supply range (VDD)	N. A.	
Max output signal	N. A.	

^a The calibrations at 2.1 to 2.5 μ m and 10.6 μ m are on special request only. The traceability at 248 nm is obtained with the help of a traceable reference at 250 nm, since our spectrophotometer has a 4 nm spectral bandwidth at 248 nm.

^b See graph at the end of this section.

^c Water temperature \leq 22°C, 1/8 NPT compression fittings for ¼ inch semi-rigid tube.

Specifications subject to change without notice.

UP50N(M)-...-W9- ...	UP50N-40S / 50H -W9 UP50M-50W -W9 Without PCB	UP50N-40S / 50H -W9 UP50M-50W -W9 With PCB
Aperture Diameter	50 mm	
Spectral Range	190 nm - 10 μ m	
Calibrated spectral range ^a	0.248 – 2.5 μ m	
Power Noise Level	10 mW with anticipation 5 mW without anticipation	6 mW with anticipation ^c 3 mW without anticipation ^c
Typical Rise Time (0 – 95 %)	16 s (3.5 s with anticipation)	
Typical sensitivity	0.12 mV/W	40S: 150 mV/W 50H: 120 mV/W 50W: 120 mV/W
Calibration Uncertainty	\pm 2.5 %	
Linearity with Power	\pm 2 %	
Repeatability (Precision)	\pm 0.5 %	
Power Resolution	\pm 0.5 %	
Max. Average Power	40S: 40 W 50H: 50 W 50W: 50 W	
Max. Average Power (1 min.) (cooling : minimum 3 min)	40S: 80 W 50H: 85 W 50W: 85 W	
Max. Average Power Density 1.064 μ m, 10W CW	100 kW/cm ²	
<u>Pulsed Laser Damage Thresholds</u>	<u>Max. Energy Density</u>	<u>Peak Power Density</u>
1.064 μ m, 150 μ s, 5 Hz	100 J/cm ²	667 kW/cm ²
1.064 μ m, 7 ns, 10 Hz	1.1 J/cm ²	157 MW/cm ²
532 nm, 7 ns, 10 Hz	1.1 J /cm ²	157 MW/cm ²
248 nm , 26 ns, 10 Hz	0.7J /cm ²	27 MW/cm ²
Dimension (mm)	40S: 89(H) x 89(W) x 32(D) 50H: 89(H) x 89(W) x 106(D) 50W: 89(H) x 89(W) x 40(D)	
Weight (head only)	40S: 0.62 kg 50H: 0.93 kg 50W: 0.81 kg	
Minimum Cooling Flow ^b	1 liter/min	
Cooling	Heat sink / Fan / Water	
Recommended load Impedance	> 100 k Ω	10 M Ω
Output Impedance	N. A.	\leq 50 Ω
Linearity vs beam dimension	\pm 0.5 %	
Power supply range (VDD)	N. A.	+12 to +16 V regulated
Max output signal	N. A.	VDD (supply)-3V, max of 12V

^a The calibrations at 2.1 to 2.5 μ m are on special request only. The traceability at 248 nm is obtained with the help of a traceable reference at 250 nm, since our spectrophotometer has a 4 nm spectral bandwidth at 248 nm.

^b Water temperature \leq 22°C, 1/8 NPT compression fittings for 1/4 inch semi-rigid tube.

^c Noise level measured using P-LINK (USB). Noise level is dependant on acquisition system.

Specifications subject to change without notice.

UP55N(M)-...-Hx- ... UP60N(M)-...-Hx- ...	UP55N-40S / 100H -H9 UP55N-300F -H12 UP55N-300DI -H12 UP55M-500W -H12 UP55M-700W -HD Without PCB	UP55N-40S / 100H -H9 UP55N-300F -H12 UP55N-300DI -H12 UP55M-500W -H12 UP55M-700W -HD With PCB	UP60N-40S / 100H -H9 UP60N-300F -H12 UP60N-300DI -H12 UP60M-500W -H12 UP60M-700W -HD Without PCB
Aperture Diameter	55 mm		60 mm
Spectral Range	190 nm - 20 μ m		
Calibrated spectral range ^a	0.248 – 2.5 μ m and 10.6 μ m		
Power Noise Level	With anticipation : H9: 10 mW H12: 30 mW HD: 90 mW Without anticipation H9 : 5 mW H12 : 15 mW HD : 45 mW	With anticipation : H9: 4mW ^d H12: 30 mW ^d HD: 90 mW ^d Without anticipation H9: 2mW ^d H12:15 mW ^d HD: 45 mW ^d	With anticipation : H9: 10 mW H12: 30 mW HD: 90 mW Without anticipation : H9: 5mW H12: 15 mW HD: 45 mW
Typical Rise Time (0 - 95 %)	H9: 11 s (2 s with anticipation) H12: 18 s (2 s with anticipation) HD: 14 s (2 s with anticipation)	H9: 2 s (with anticipation) H12: 3 s (with anticipation) HD: 5s (with anticipation)	H9: 11 s (2 s with anticipation) H12: 18 s (2 s with anticipation) HD: 14 s (2 s with anticipation)
Typical sensitivity	H9: 0.12 mV/W H12: 0.06 mV/W HD: 0.03mV/W	40S: 150 mV/W 100H: 60 mV/W 300F: 20 mV/W 300DI : 20mV/W 500W: 15 mV/W 700W: 8 mV/W	H9: 0.12 mV/W H12: 0.06 mV/W HD: 0.03mV/W
Calibration Uncertainty	$\pm 2.5\%$		
Linearity with Power	$\pm 2\%$		
Repeatability (Precision)	$\pm 0.5\%$		
Power Resolution	$\pm 0.5\%$		
Max. Average Power	40S: 40 W 100H: 100 W 300F: 300 W 300DI : 300W 500W: 500 W 700W: 700 W		
Max. Average Power (1 min.) (cooling : minimum 3 min)	40S: 80 W 100H: 200 W 300F: 300 W 300DI : 300W 500W: 500 W 700W: 700 W		
Max. Average Power Density ^b 1.064 μ m, 10 W CW 10.6 μ m, 10 W CW	45 kW/cm ² 14 kW/cm ²		
Pulsed Laser Damage Thresholds 1.064 μ m, 360 μ s, 5 Hz 1.064 μ m, 7 ns, 10 Hz 532 nm, 7 ns, 10 Hz 266 nm, 7 ns, 10 Hz	<u>Max. Energy Density</u> 9 J/cm ² 1.0 J/cm ² 0.6 J/cm ² 0.3 J/cm ²	<u>Peak Power Density</u> 25 kW/cm ² 143 MW/cm ² 86 MW/cm ² 43 MW/cm ²	
Dimension (mm)	40S: 89(H) x 89(W) x 32(D) 100H: 89(H) x 89(W) x 106(D) 300F: 89(H) x 89(W) x 116(D) 300DI : 89(H) x 89(W) x 44(D) 500W / 700W: 89(H) x 89(W) x 40(D)		
Weight (head only)	40S: 0.62 kg 100H: 0.93 kg 300F: 1.41 kg 300DI : 1.68 kg 500W: 0.81 kg 700W: 0.90 kg		
Minimum Cooling Flow ^c	1.5 liter/min		
Cooling	Heat sink / Fan / Water		
Recommended load Impedance	> 100 k Ω	10 M Ω	> 100 k Ω
Output Impedance	N. A.	$\leq 50\ \Omega$	N. A.
Linearity vs beam dimension	$\pm 0.5\%$		
Power supply range (VDD)	N. A.	+12 V to +16 V regulated	N. A.
Max output signal	N. A.	VDD (supply)-3V, max of 12V	N. A.

^a The calibrations at 2.1 to 2.5 μm and 10.6 μm are on special request only. The traceability at 248 nm is obtained with the help of a traceable reference at 250 nm, since our spectrophotometer has a 4 nm spectral bandwidth at 248 nm.

^b See graph at the end of this section.

^c Water temperature $\leq 22^\circ\text{C}$, 1/8 NPT compression fittings for 1/4 inch semi-rigid tube. For the stainless steel water module, the minimum cooling flow is 1.0 liter/min for power higher than 90 W.

^d Noise level measured using P-LINK (USB). Noise level is dependant on acquisition system.

Specifications subject to change without notice.

UP55N(M)-...-VR-...	UP55N-50S/100H/150F-VR UP55M-200W-VR Without PCB	UP55N-50S/100H/150F-VR UP55M-200W-VR With PCB
Aperture Diameter	55 mm	
Spectral Range	300 nm – 2.5 μm	
Calibrated spectral range ^a	0.30 – 2.5 μm	
Power Noise Level	30mW with anticipation 15 mW without anticipation	30mW with anticipation ^d 15 mW without anticipation ^d
Typical Rise Time (0 - 95 %)	4 s 50 s (without anticipation)	5 s (with anticipation)
Typical sensitivity	0.04 mV/W	50S : 120 mV/W 100 H : 60 mV/W 150 F : 40 mV/W 200 W : 30 mV/W
Calibration Uncertainty	$\pm 2.5 \%$	
Linearity with Power	$\pm 2 \%$	
Repeatability (Precision)	$\pm 0.5 \%$	
Power Resolution	$\pm 0.5 \%$	
Max. Average Power	50S : 50 W 100H : 100 W 150F : 150 W 200W : 200 W	
Max. Average Power (1 min.) (cooling : minimum 3 min)	50S : 50 W 100H : 100 W 150F : 150 W 200W : 200 W	
Max. Average Power Density ^b 1.064 μm , 10 W CW	700 W/cm ²	
<u>Pulsed Laser Damage Thresholds</u> 1.064 μm , 7 ns, 10 Hz 532 nm, 7 ns, 10 Hz 266 nm, 7 ns, 10 Hz 1.064 μm , 360 μs , 5 Hz	<u>Max. Energy Density</u> 6 J/cm ² 4 J/cm ² 1 J/cm ² 40 J/cm ²	<u>Peak Power Density</u> 860 MW/cm ² 570 MW/cm ² 143 MW/cm ² 111 kW/cm ²
Dimension (mm)	50S : 89(H) x 89(W) x 32(D) 100H : 89(H) x 89(W) x 106(D) 150F : 89(H) x 89(W) x 116(D) 200W : 89(H) x 89(W) x 40(D)	
Weight (head only)	50S : 0.62 Kg 100H : 0.93 Kg 150F : 1.41 Kg 200W : 0.84 Kg	
Minimum Cooling Flow ^c	1 liter/min	
Cooling	Heat sink / Fan / Water	
Recommended load Impedance	> 100 k Ω	10 M Ω
Output Impedance	N. A.	$\leq 50 \Omega$
Linearity vs beam dimension	$\pm 0.5 \%$	
Power supply range (VDD)	N. A.	+12 V to +16 V regulated
Max output signal	N. A.	VDD (supply)-3V, max of 12V

^a The calibrations at 2.1 to 2.5 μm are on special request only. The traceability at 248 nm is obtained with the help of a traceable reference at 250 nm, since our spectrophotometer has a 4 nm spectral bandwidth at 248 nm..

^b See graph at the end of this section.

^c Water temperature $\leq 22^\circ\text{C}$, 1/8 NPT compression fittings for 1/4 inch semi-rigid tube.

^d With PCB : Noise level measured using P-LINK (USB). Noise level is dependant on acquisition system.

Specifications subject to change without notice.

UP55C-2.5KW-HD	UP55C-2.5KW-HD Without PCB	
Effective Aperture Diameter	55 mm	
Spectral Range	0.19 μm - 20 μm	
Calibrated spectral range ^a	0.248 – 2.5 μm and 10.6 μm	
Power Noise Level	± 0.4 W with anticipation ± 0.2 W without anticipation	
Typical Rise time (0 - 95 %)	3.5 s (25 s without anticipation)	
Typical sensitivity	8 $\mu\text{V/W}$	
Calibration Uncertainty	± 2.5 %	
Linearity with Power	± 2 %	
Repeatability (Precision)	± 0.5 %	
Max. Average Power	2500 W	
Max. Average Power Density		
1.064 μm , 500W CW	9.0 kW/cm ²	
1.064 μm , 1500W CW	7.0 kW/cm ²	
1.064 μm , 2500W CW	6.0 kW/cm ²	
Max. Average Power Density		
10.6 μm , 500W CW	4.5 kW/cm ²	
10.6 μm , 1500W CW	3.5 kW/cm ²	
10.6 μm , 2500W CW	3.0 kW/cm ²	
<u>Pulsed Laser Damage Thresholds</u>	<u>Max. Energy Density</u>	<u>Peak Power Density</u>
1064 nm, 7 ns, 10 Hz	1.0 J/cm ²	143 MW/cm ²
532 nm, 7 ns, 10 Hz	0.6 J/cm ²	86 MW/cm ²
Dimension (mm)	116(H) x 116(W) x 48(D)	
Weight (head only)	1.95 kg	
Cooling	Water	
Recommended Cooling Flow ^b	3-4 liter/min	
Recommended load Impedance	100 k Ω	
Output Impedance	N. A.	
Linearity vs beam dimension	± 1 %	
Power supply range (VDD)	N. A.	
Max output signal	N. A.	

^a The calibrations at 2.1 to 2.5 μm and 10.6 μm are on special request only. The traceability at 248 nm is obtained with the help of a traceable reference at 250 nm, since our spectrophotometer has a 4 nm spectral bandwidth at 248 nm.

^b Water temperature $\leq 22^\circ\text{C}$, 1/8 NPT compression fittings for 1/4 inch semi-rigid tube.

Specifications subject to change without notice.

UP55G-...-HX-... UP60G-...-HX-...	UP55G-500F-H12 UP55G-600F-HD Without PCB	UP60G-400F-H12 UP60G-500F-HD Without PCB
Aperture Diameter	55 mm	60 mm
Spectral Range	190 nm - 20 μm	
Calibrated spectral range ^a	0.248 – 2.5 μm and 10.6 μm	
Power Noise Level	With anticipation : H12 : 30 mW HD : 90 mW Without anticipation : H12 : 15 mW HD : 45 mW	
Typical Rise Time (0 – 95 %)	H12 : 16.6 s (2.8 s with anticipation) HD : 14 s (2.8 s with anticipation)	
Typical sensitivity	H12 : 0.06 mV/W HD : 0.03 mV/W	
Calibration Uncertainty	± 2.5%	
Linearity with Power	± 2%	
Repeatability (Precision)	± 0.5%	
Power Resolution	± 0.5%	
Max. Average Power	H12 : 500 W HD : 600 W	H12 : 400 W HD : 500 W
Max. Average Power (1 min.)	H12 : 500 W HD : 600 W	H12 : 400 W HD : 500 W
Max. Average Power Density ^b 1.064 μm, 10 W, CW 1.064 μm, 500 W, CW	45 kW/cm ² 8 kW/cm ²	
<u>Pulsed Laser Damage Thresholds</u>	<u>Max. Energy Density</u>	<u>Peak Power Density</u>
1.064 μm, 360 μs, 5 Hz	9 J/cm ²	25 kW/cm ²
1.064 μm, 7 ns, 10 Hz	1.0 J/cm ²	143 MW/cm ²
532 nm, 7 ns, 10 Hz	0.6 J/cm ²	86 MW/cm ²
266 nm, 7 ns, 10 Hz	0.3 J/cm ²	43 MW/cm ²
Dimensions (mm)	120(H) x 120(W) x 135(D)	
Weight (head only)	2.75 kg	
Cooling	Fan	
Recommended load Impedance	> 100 kΩ	
Output Impedance	N. A.	
Linearity vs beam dimension	± 0.5 %	
Power supply range (VDD)	N. A.	
Max output signal	N. A.	

^a The calibrations at 2.1 to 2.5 μm and 10.6 μm are on special request only. The traceability at 248 nm is obtained with the help of a traceable reference at 250 nm, since our spectrophotometer has a 4 nm spectral bandwidth at 248 nm.

^b See graph at the end of this section.

Specifications subject to change without notice.

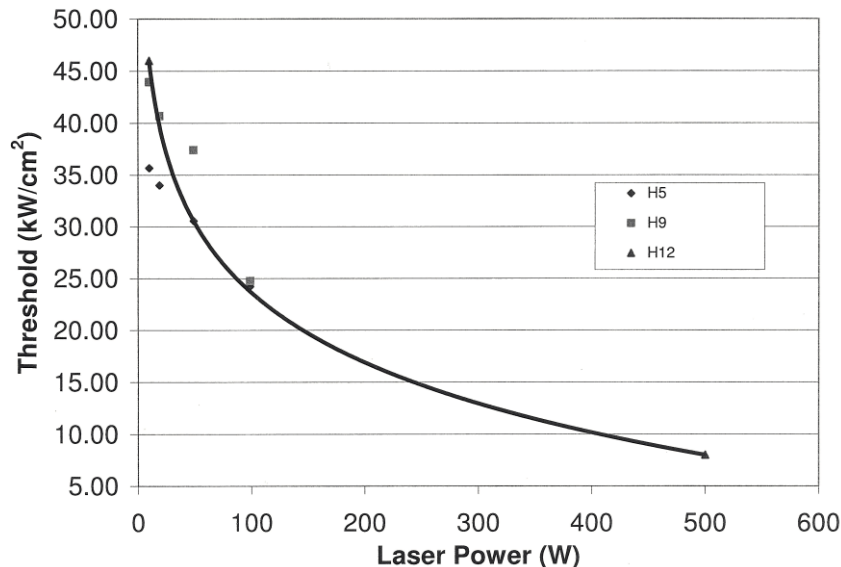
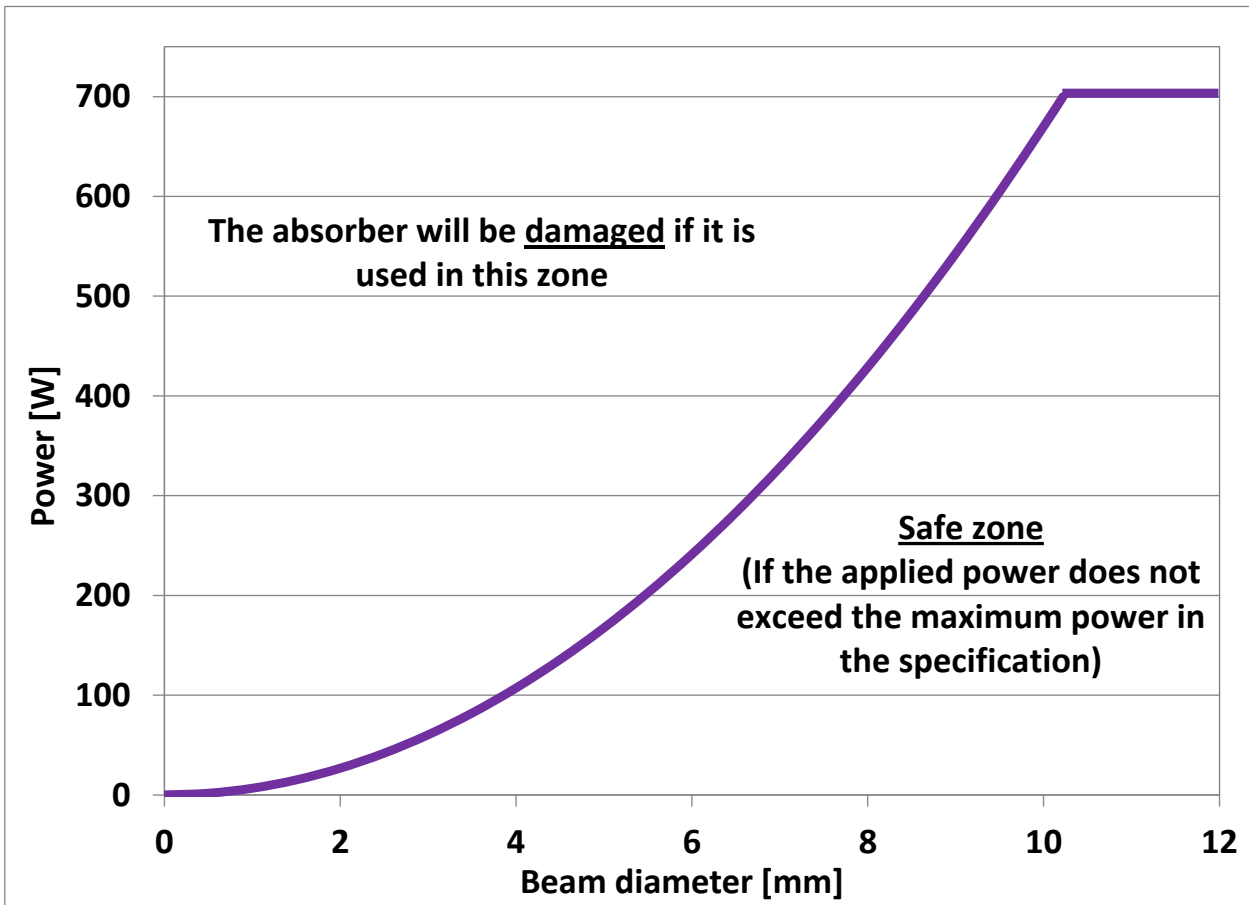

FIG. 1-9 MAX AVERAGE POWER DENSITY FOR UP WITH H-TYPE ABSORBER AT 1.064 μM .FIG. 1-10 MINIMUM BEAM SIZES FOR UP WITH H-TYPE ABSORBER AT 1.064 μM .

1.4 UP CALORIMETER MODE SPECIFICATIONS

The UP Ultra Series has an optional mode that is called calorimeter mode. It allows you to measure single shot pulse energy. This mode is accessible when you use a UP with a Gentec-EO monitor or with your own data acquisition system. For more information, refer to the monitor's instruction manual or call Customer Support at Gentec-EO, see p. ii, **Contacting Gentec Electro-Optics Inc.**

		XLP(F) "..." H2 25 F : 22.5	UP12E "..." H5	UP10P "..." H5	UP10K "..." H5	UP17P "..." H5	UP17P "..." W5
Typical sensitivity	mV/J		0.84	2.4	2.4	0.7	0.2
Power sensitivity / Energy sensitivity	J/W	8	0.63	0.81	0.81	0.86	3
Typical rise time in calorimeter mode	ms	1000	150	190	190	328	575
Minimum repetition period	sec	16	1.5	2	2	4	5
Maximum pulse width	ms	300	50	63	63	88	133
Maximum measurable energy ^a	J	5	5	3	3	15	200
Noise equivalent energy	mJ	0.012	20	5	5	20	20
Accuracy	%	± 5	± 5	± 5	± 5	± 5	± 5%

		UP19K "..." H5	UP19K "..." H9	UP19K "..." VR	UP19K "..." W5
Typical sensitivity	mV/ J	0.65	0.23	0.10	0.33
Power sensitivity / Energy sensitivity	J/W	0.99	1	3.4	2
Typical rise time in calorimeter mode	ms	264	264	270	400
Minimum repetition period	sec	4	4	4.5	5
Maximum pulse width	ms	88	88	90	133
Maximum measurable energy ^a	J	15	25	40	200
Noise equivalent energy	mJ	20	60	20	23
Accuracy	%	± 5%	± 5%	± 5	± 5

		UP25N, "..." H9	UP25N, UP25M "..." H12	UP25T "..." H12	UP50N, UP50M "..." W9	UP55N, UP60N "..." H9	UP55N UP55M "..." VR	UP55N, UP55M, UP60N, UP60M "..." H12
Typical sensitivity	mV/J	0.14	0.05	0.05	0.020	0.028	0.010	0.015
Power sensitivity / Energy sensitivity	J/W	1.67	2.19	2.19	5.28	4.25	4.25	4.46
Typical rise time in calorimeter mode	ms	370	1300	1300	1400	1300	1300	1600
Minimum repetition period	sec	4.6	11.5	11.5	11.1	11.1	11.1	12
Maximum pulse width	ms	123	390	390	467	433	433	430
Maximum measurable energy ^a	J	40	40	40	500	200	500	200
Noise equivalent energy	mJ	200	200	200	250	250	250	250
Accuracy	%	± 5	± 5	± 5%	± 5%	± 5%	± 5%	± 5

		UP55G, UP60G "..." H12	UP55C "..." HD	UP55M, UP55G, UP60M, UP60G "..." HD
Typical sensitivity	mV/J	0.013	0.0025	0.008
Power sensitivity / Energy sensitivity	J/W	4.62	3.19	4.46
Typical rise time in calorimeter mode	ms	1800	855	1600
Minimum repetition period	sec	14.3	11	12
Maximum pulse width	ms	433	210	430
Maximum measurable energy ^a	J	200	200	200
Noise equivalent energy	mJ	250	1300	250
Accuracy	%	± 5	± 5	± 5

^a For 1,064 μm ; 360 μs pulses.

Higher pulse energy possible when customized for long pulse (ms), lower for short pulses (ns).

Specifications subject to change without notice.

1.5 UP POTENTIOMETER POSITIONS

The UP with amplification has 3 holes on top of the detector for the UP12E, UPXXK and the UP25T and on the left side of the detector for the UP25N(M), UP50N(M), UP55N(M) and the UP60N(M) giving access to the potentiometers to adjust the gain, the anticipation and the offset, as shown in figure 1-8.

WARNING : If you are using Gentec-EO calibration, **DO NOT** change the potentiometer settings because this would invalidate factory calibration.

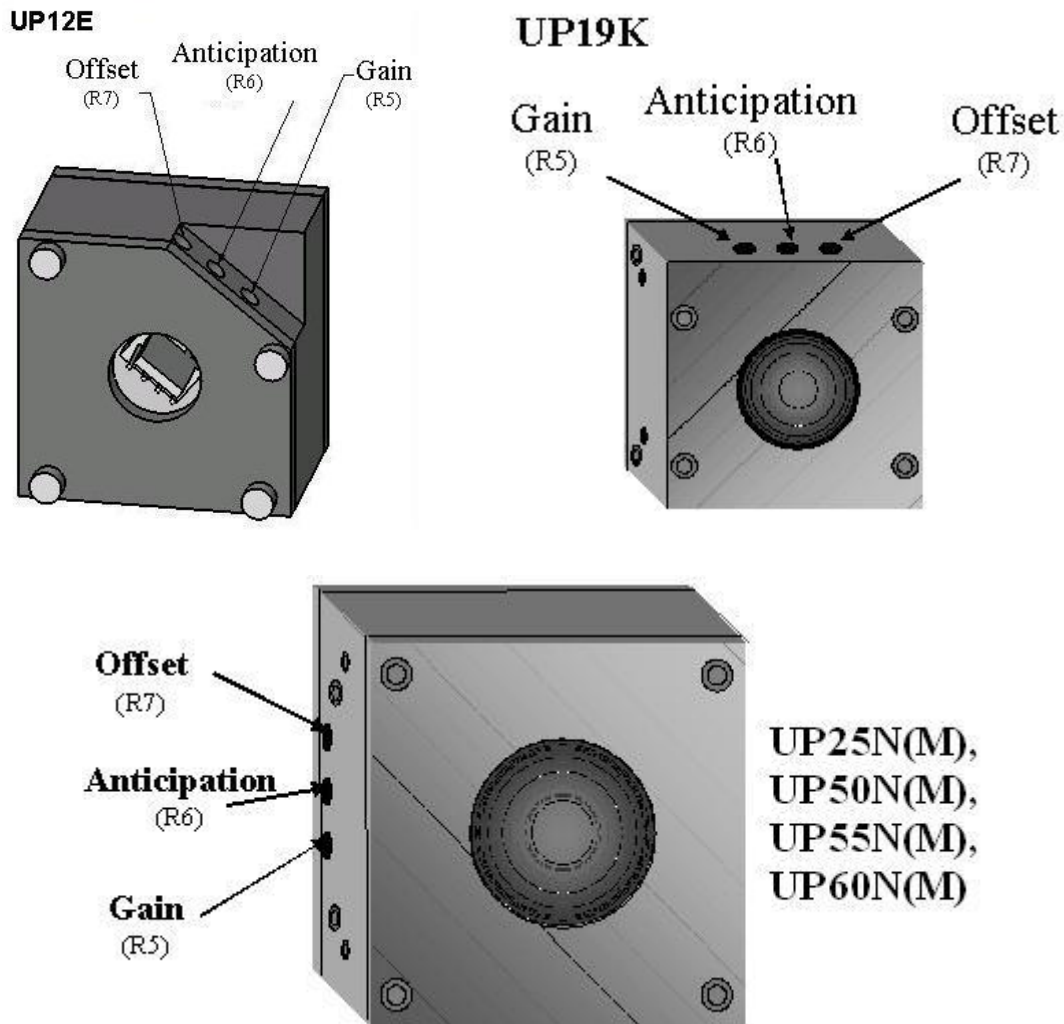

FIG. 1-11 POTENTIOMETER POSITIONS

1.6 USING A CUSTOMER-SUPPLIED HEAT SINK

This is a special case. Standard detectors are calibrated and shipped complete with a Gentec-EO heatsink or back module installed. However, should the customer wish to install an alternative heatsink or back module, the following indications should be followed. This does not apply to the XLP, UP_P, UP_T, UP_M, and UP_G series.

Instructions :

1. Required specifications for customer-supplied back module are given in Fig 1-10 through 1-12. Note that tapped holes must be electrically conductive, and that there has to be at least bare spots to allow electrical contact with detector (see point 5.).
2. While keeping together the front cover and the central housing, remove the four front screws of the UP detector.
3. Discard the back module.
4. Apply electrically-conductive silver epoxy on the bare contact zones of the back module (*Tra-Con, Tra-Duct no. BA-2902*). This will ensure proper electrical contact between the new back module and the central housing.
5. Apply thermal paste (such as *Wakefield Engineering Inc. thermal paste part no. 120-2*) on the remainder of back module. This will ensure proper thermal contact with the new back module.
6. In the case that both central housing and back module are entirely bare and electrically conducting, a grease that is both thermally and electrically conductive (*Timtronics Black Ice 712*) may be applied, instead of steps 4. and 5.
7. Install the new back module onto the detector using the the four original screws. It is strongly advised to apply removable thread locker (*Loctite removable thread locker 242*) on the screws before inserting them. The recommended torque for each of the 4 screws is 6 in.lbs. (70 Ncm).

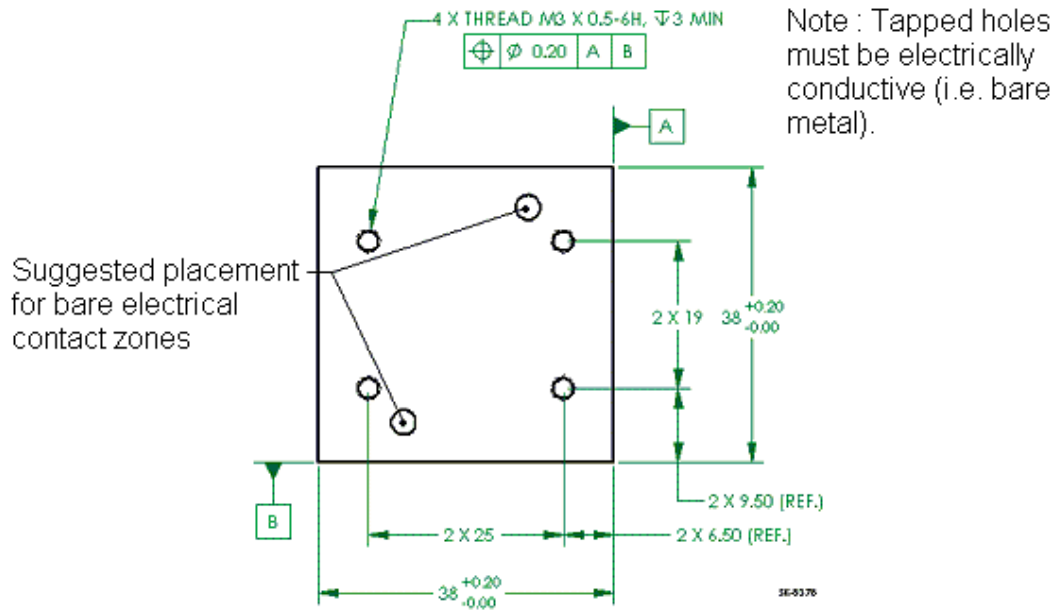

FIG. 1-12 TAPPED HOLE POSITIONS FOR UP12E, WITHOUT PCB

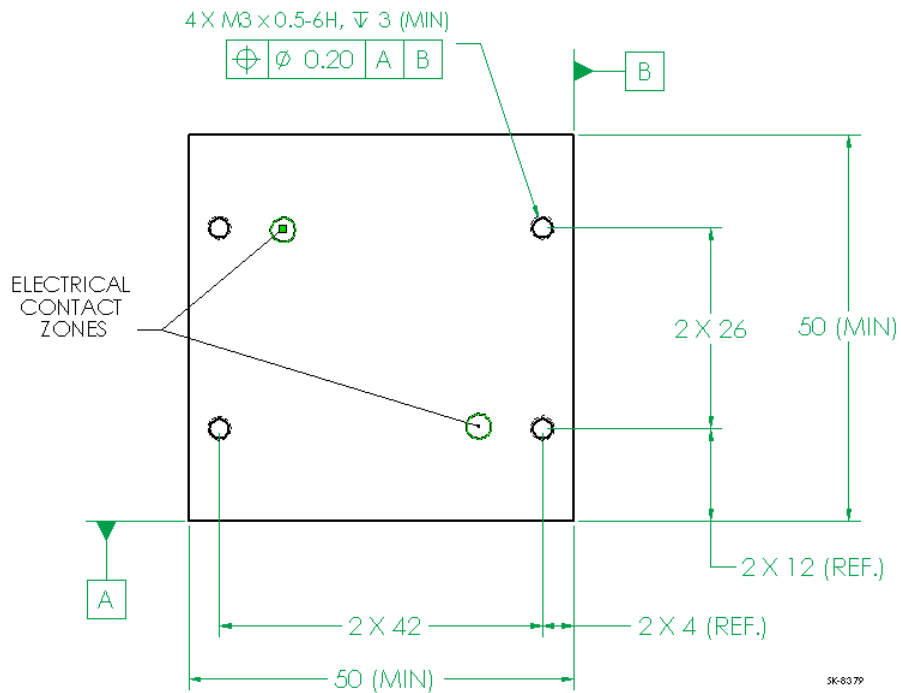

FIG 1-13 TAPPED HOLE POSITIONS FOR UPXXK

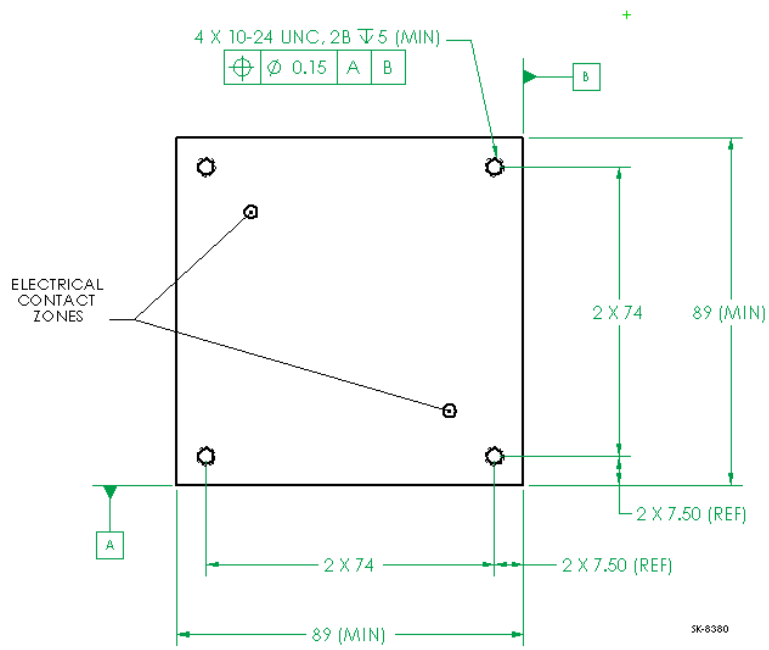

FIG 1-14 TAPPED HOLE POSITIONS FOR UP25N, UP50N(M), UP55N(M), AND UP60(M)

2 OPERATING INSTRUCTIONS

In order to ensure a long lifetime of accurate measurements, it is recommended that UP wattmeters be held within the following ambient conditions stated in the specifications.

For a fan-cooled UP, connect the fan to the proper power supply.

NOTE: The UP55G and UP60G must only be used with the Gentec-EO Power Supply P/N 201103.

For a water-cooled UP, connect the detector head to a an cooling water supply. The water-cooled UP is equipped with ¼" tube fittings .

NOTE: The end of the tube must be cut perpendicular to the tubing; the portion of the outer tubing wall that slips into the fitting must not be deformed or damaged, otherwise the connection will not be water-tight.

To connect the detector head fittings to the water supply tubing, unscrew the two parts of the fitting, push the tubing into the part not connected to the detector until it comes to the end of the fitting; then screw in the two parts of the fitting.

The direction of flow through the head is unimportant. Once you have connected the fittings, check them for leaks. If you find a leak, check to see if the tubes are pushed in far enough and that the tubing has not been damaged.

Verify that the flow rate satisfies the minimum values, as indicated on the specifications pages. A flow rate of at least 1 l/min is recommend for most models. Time variations of water flow rates or water temperature may cause corresponding oscillations in measurements.

To disconnect the detector head fittings, remove the water pressure and drain the water from the tubing. Unscrew the two parts of the fitting and pull out the tubing.

NOTE: Water will usually remain in the detector head after it is disconnected. The detector should be completely dried out with an air flow before being stored. Be careful not to blow the water on yourself or on the detector aperture.

Once appropriate cooling is achieved, the UP is ready to be aligned in the intended optical set-up.

1. Remove the power detector cover.
2. Align the detector in the optical set-up, using a safe low-powered beam.
3. For the most accurate measurements, the beam should be centered on the sensor face. The beam diameter on the sensor should ideally be the same size as the beam diameter of the original calibration, which corresponds to >98% encircled power centered on 50% of the sensor's surface (this complies with the International Electrotechnical Commission standard #1040: "Power and Energy Measuring Detector..."). Refer to calibration certificate for the exact calibration beam diameter.

WARNING: Be careful not to exceed the maximum levels and densities stated in the specifications.

2.1 WITH ANY GENTEC-EO MONITOR

To make a measurement Gentec-EO monitor, continue with the following steps:

4. Connect the detector head to the input socket on the monitor (see the monitor's instruction manual).
5. Block off the detector head to prevent it from sensing heat from random sources.
6. Once the reading is thermally stable, the reading should be set to 0 W with the monitor's Zero (Offset) function (see the monitor's instruction manual).
7. Allow the detector head to thermally stabilize before making any subsequent measurement reading.

2.2 WITHOUT A GENTEC-EO MONITOR

To make a measurement without a Gentec-EO monitor, continue with the following steps:

4. Let the head thermally stabilize for at least 10 minutes, and set up cooling (if fan- or water-cooled).
5. Connect the power head to a precision microvoltmeter, or data acquisition system, with a load impedance that is $>100 \text{ k}\Omega$ (UP without internal circuit board) or with a load impedance $>10 \text{ M}\Omega$ (UP with internal circuit board). Because of the very low voltages at lower power levels for some of these detectors, analog or digital filtration may be required to remove ambient electrical noise.
6. Put the power head into the laser beam path (the laser beam must be contained within the sensor area) for about one minute.
7. Block off any laser radiation to the detector.
8. Switch on the microvoltmeter and adjust its voltage range to the range required for the range required for the measurement. To determine the voltage range to be measured, refer to the detector head specifications:

$$V_{out} = (\text{expected power}) \times (\text{calibration sensitivity of power detector})$$

9. Wait until the signal has stabilized (fluctuations representing less than 1% of the voltage level being measured are negligible) then, measure the zero level voltage offset from the detector. Strong fluctuations in the zero level are usually caused by one of the following:
 - Rapid fluctuations in the rate of water flow.
 - Rapid fluctuations in water temperature.
 - Strong drafts or stray radiation (especially visible when you are taking low power measurements)
 - Ambient electrical noise (should be filtered out).
10. Apply the laser beam to the power head.
11. Wait until the signal has stabilized (between one to three minutes for optimum measurements), then measure the voltage output from the detector (refer to specifications pages for individual head 0-95% non anticipated response times).
12. The measured power is calculated as follows:

$$\begin{aligned} \text{Measured power[W]} &= (\text{output voltage[V]} - \text{zero level voltage[V]}) / \text{calibration sensitivity[V/W]} \\ &= 1000 \times (\text{Vout[mV]} - \text{Vzero level[mV]}) / \text{calibration sensitivity[mV/W]} \end{aligned}$$

2.3 SAFETY OPERATION NOTES

Diffusive surfaces

When using the UP with a coating H, W, and VR be aware of the diffused back reflection:

- H and W: ~ 5-15%
- VR: ~ 40-45%

As on any diffusive surface, the light on the sensor coating is scattered more or less uniformly as a Lambertian diffuser. It is recommended to use the head with a black protective sleeve. This will limit wide-angled diffused reflections.

Detector temperature while in operation

During usage, detectors can become hot enough to cause burns.

3 DAMAGE TO THE OPTICAL ABSORBER MATERIAL

Damage to the optical absorber material is usually caused by exceeding the manufacturer's specifications, such as:

- Incident Average Power Density
- Incident Pulse Energy Density

Refer to the specifications pages for the Ultra Series UP power head specifications. Damage may also be caused if the absorber surface is contaminated. A slight discoloration of the coating does not affect the calibration.

In any case, the beam's incident area should not be less than 10% of the detector's aperture. Please contact Gentec-EO to make measurements with such smaller beams.

In the event of significant damage to the coating, the Ultra Series UP sensors can be recoated. Contact your local Gentec-EO representative for information on repair and recalibration. See p. ii **Contacting Gentec Electro-Optics Inc.**

Appendix A: WEEE directive

1.1 Recycling and separation procedure for WEEE directive 2002/96/EC:

This section is used by the recycling center when the detector reaches its end of life. Breaking the calibration seal or opening the monitor will void the detector warranty.

The complete Detector contains

- 1 Detector with wires or DB-15.
- 1 instruction manual
- 1 calibration certificate
- 1 Electronic PCB (Integra option)
- 1 Plastic enclosure (Integra option)

1.2 Separation:

Paper : Manual and certificate

Wires: Cable Detector.

Printed circuit board: inside the Detector (for -MT, -MA, -BT and -CP version only) or DB-15, no need to separate (less than 10 cm²). Inside the integra enclosure, no need to separate (less than 10 cm²).

Aluminum: Detector casing.

Plastic: Integra enclosure.

DECLARATION OF CONFORMITY

Application of Council Directive(s): 2014/30/EU EMC Directive

Manufacturer's Name: Gentec Electro Optics, Inc.
 Manufacturer's Address: 445 St-Jean Baptiste, suite 160
 (Québec), Canada G2E 5N7

Representative's Name: Laser Component S.A.S
 Representative's Address: 45 bis Route des Gardes
 92190 Meudon (France)

Type of Equipment: Laser Power/Energy Meter
 Model No.: UP, XLP series

Year of test & manufacture: 2016

Standard(s) to which Conformity is declared:
 EN 61326-1: 2006 Emission generic standard

Standard	Description	Performance Criteria
CISPR 11 :2009 A1 :2010	Industrial, scientific and medical equipment – Radio-frequency disturbance characteristics – Limits and methods of measurement	Class A
EN 61000-4-2 2009	Electromagnetic compatibility (EMC) – Part 4-2: Testing and measurement techniques- Electrostatic discharge.	Class B
EN61000-4-3 2006+A2:2010	Electromagnetic compatibility (EMC) – Part 4-3: Testing and measurement techniques- Radiated, Radio Frequency, electromagnetic field immunity test.	Class A
EN61000-4-4 2012	Electromagnetic compatibility (EMC) – Part 4-4: Testing and measurement techniques- Electrical fast transient/burst immunity test.	Class B
EN 61000-4-5 2006	Electromagnetic compatibility (EMC) – Part 4-5: Testing and measurement techniques- Surge immunity test.	Class B
EN 61000-4-6 2013	Electromagnetic compatibility (EMC) – Part 4-6: Testing and measurements techniques- Immunity to conducted Radio Frequency.	Class A
EN 61000-4-11 2004	Electromagnetic compatibility (EMC) – Part 4-11: Testing and measurement techniques- Voltage dips, short interruptions and voltage variations immunity tests. Voltage dips: 0% during 1 cycle 40% during 10 cycles 70% during 25 cycles Short interruptions: 0% during 250 cyles	Class B Class B Class C Class C

EN 61000-3-2:2006 +A1:2009	Electromagnetic compatibility (EMC) - Part 3-2: Limits - Limits for harmonic current emissions (equipment input current <= 16 A per phase)	Class A
-------------------------------	--	---------

I, the undersigned, hereby declare that the equipment specified above conforms to the above Directive(s) and Standard(s)

Place: Quebec (Quebec)

Date : July 14 2016



(President)

Appendix B: Using the XLP12 with the XLP12 filter:

The XLP12 filter features ease of installation and removal. To use an XLP12 series wattmeter (@ any wavelength) with the XLP12 filter, the user must calibrate the assembly using the following procedure:

Step 1: Set up the XLP12 wattmeter without the filter to measure the power of your laser. Adjust the sensitivity of the wattmeter to your working wavelength. Verify that the power level is below the detector's damage threshold and that the laser has a good stability.

Step 2: Warm up the detector by applying power to it for a few minutes. This will reduce thermal bias.

Step 3: Measure the power level (without the filter). To reduce random uncertainty, we recommend taking the average of 5 distinct measurements.

Step 4: Install the filter. Without changing the laser settings, measure the power level by averaging the same number of distinct measurements as in Step 3. All laser settings remain identical as in Step 3, including beam size and position on detector.

Step 5: Repeat the first measurement (Step 3) to verify that there hasn't been any change during the procedure that would invalidate the calibration. A difference that is larger than the uncertainty of your measurement means that something in the laser or environment changed. You may add this to your \pm uncertainty when using the filter or you may try stabilizing the laser and environment and repeat from Step 3.

The correction multiplier for the Duo (rev 2.0) and the Solo will be given by:

$$T_f = \frac{\text{Reading without attenuator}}{\text{Reading with attenuator}} \text{ (no units)}$$

The correction factor for the Duo (prior to rev 2.0) will be:

$$F_s = \frac{100}{T_f} (\%)$$

Now use calibration factor F_s for the filter when using it at the wavelength established in Step 1.

<u>XLP12 Filter</u>	
Spectral Range	280 nm – 1.36 μ m
Typical Transmittance (@ 1.064 μ m)	93 %
Typical Reflectance (@ 1.064 μ m)	7 %
Dimensions (installed in own mount and XLP12, ext. \varnothing x thickness)	1.2 " x 1/3 "

FIG. 1-15 XLP12 FILTER SPECIFICATIONS

Appendix C: Using the XLP12 with an optical fiber adaptor:

When fitted with an appropriate adaptor, such as Gentec-EO's FC Optical Fiber Connector, the XLP12 can be used to measure the output of an optical fiber. When using an optical fiber adaptor, it is the user's responsibility to ensure that the entire output of the fiber is incident upon the detector's absorbing surface. Figure 1-10 and the following inequation are provided as a guide to verify this.

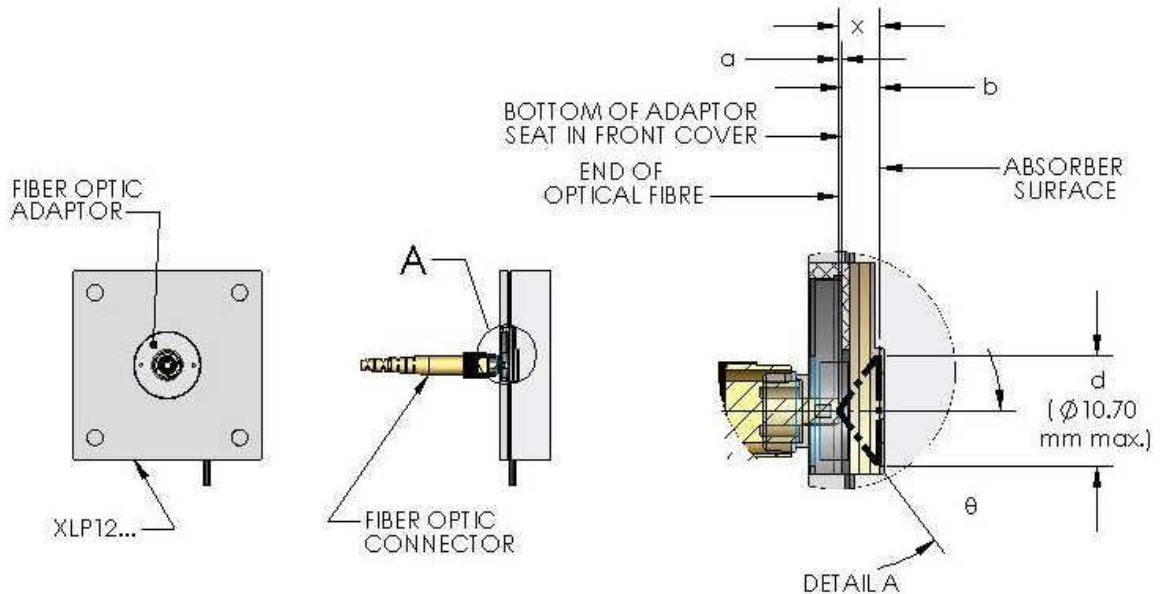

FIG. 1-16 USING AN OPTICAL FIBER ADAPTOR

For the XLP12, the distance in mm between the absorbing surface and the adaptor seat is $b = 3.75 \pm 0.5$. The diameter in mm corresponding to 80% of the absorbing surface (80% is a common value for allowing sufficient margin to avoid edge effects) is $d = 10.7$. The acceptance angle θ of the fiber is specific to the user's fiber, as is the value of a , the distance in mm between the end of the fiber and the interface between the adaptor and its seat on the detector. This value can be measured once the user's fiber is connected to the fiber adaptor (a typical value may be $a = 0.2$ mm). Once known, the values θ and a can be entered in the following inequation:

$$(a + 4) \tan \theta < 5.35,$$

Where, 5.35 is $d/2$. If the inequation is verified, then it is safe to consider that the light cone, having a height $x = a + b$ and a maximum diameter d , exiting the fiber is entirely incident on 80% of the measuring surface of the detector.



LEADER IN LASER BEAM MEASUREMENT SINCE 1972

POWER & ENERGY METERS



BEAM PROFILING



TERAHERTZ MEASUREMENT



CANADA

445 St-Jean-Baptiste, Suite 160
Quebec, QC, G2E 5N7, Canada
T (418) 651-8003
F (418) 651-1174
1 (888) 5GENTEC (Canada and USA only)
info@gentec-eo.com

UNITED STATES

5825 Jean Road Center
Lake Oswego, OR, 97035, USA
T (503) 697-1870
F (503) 697-0633
1 (888) 5GENTEC (Canada and USA only)
info@gentec-eo.com

CALIBRATION CENTERS

445 St-Jean-Baptiste, Suite 160
Quebec, QC, G2E 5N7, Canada
Werner von Siemens Str. 15
82140 Olching, Germany
1-11-14, Kasuga, Bunkyo-ku,
Tokyo 112-0003, Japan